



power contactor, AC-3e/AC-3 185 A, 90 kW / 400 V AC (50-60 Hz) / DC U<sub>c</sub>: 96-127 V PLC input 24 V DC 3-pole, auxiliary contacts 2 NO + 2 NC drive: electronic main circuit: busbar control and auxiliary circuit: spring-loaded terminal

<b>product brand name</b>	SIRIUS
<b>product designation</b>	Power contactor
<b>product type designation</b>	3RT1
<b>General technical data</b>	
<b>size of contactor</b>	S6
<b>product extension</b>	
• function module for communication	No
• auxiliary switch	Yes
<b>power loss [W] for rated value of the current</b>	
• at AC in hot operating state	39 W
• at AC in hot operating state per pole	13 W
• without load current share typical	2.8 W
<b>type of calculation of power loss depending on pole</b>	quadratic
<b>insulation voltage</b>	
• of main circuit with degree of pollution 3 rated value	1 000 V
• of auxiliary circuit with degree of pollution 3 rated value	500 V
<b>surge voltage resistance</b>	
• of main circuit rated value	8 kV
• of auxiliary circuit rated value	6 kV
maximum permissible voltage for protective separation between coil and main contacts according to EN 60947-1	690 V
<b>shock resistance at rectangular impulse</b>	
• at AC	8,5g / 5 ms, 4,2g / 10 ms
• at DC	8,5g / 5 ms, 4,2g / 10 ms
<b>shock resistance with sine pulse</b>	
• at AC	13,4g / 5 ms, 6,5g / 10 ms
• at DC	13,4g / 5 ms, 6,5g / 10 ms
<b>mechanical service life (operating cycles)</b>	
• of contactor typical	10 000 000
• of the contactor with added electronically optimized auxiliary switch block typical	5 000 000
• of the contactor with added auxiliary switch block typical	10 000 000
<b>reference code according to IEC 81346-2</b>	Q
<b>Substance Prohibitance (Date)</b>	
<b>SVHC substance name</b>	Lead - 7439-92-1
<b>Weight</b>	3.353 kg
<b>Ambient conditions</b>	
installation altitude at height above sea level maximum	2 000 m
<b>ambient temperature</b>	
• during operation	-25 ... +60 °C
• during storage	-55 ... +80 °C

relative humidity minimum	10 %
relative humidity at 55 °C according to IEC 60068-2-30 maximum	95 %
<b>Main circuit</b>	
number of poles for main current circuit	3
number of NO contacts for main contacts	3
<b>operating voltage</b>	
• at AC-3 rated value maximum	1 000 V
• at AC-3e rated value maximum	1 000 V
<b>operational current</b>	
• at AC-1 at 400 V at ambient temperature 40 °C rated value	215 A
• at AC-1	
— up to 690 V at ambient temperature 40 °C rated value	215 A
— up to 690 V at ambient temperature 60 °C rated value	185 A
— up to 1000 V at ambient temperature 40 °C rated value	100 A
— up to 1000 V at ambient temperature 60 °C rated value	100 A
• at AC-3	
— at 400 V rated value	185 A
— at 500 V rated value	185 A
— at 690 V rated value	170 A
— at 1000 V rated value	65 A
• at AC-3e	
— at 400 V rated value	185 A
— at 500 V rated value	185 A
— at 690 V rated value	170 A
— at 1000 V rated value	65 A
• at AC-4 at 400 V rated value	160 A
• at AC-5a up to 690 V rated value	189 A
• at AC-5b up to 400 V rated value	153 A
• at AC-6a	
— up to 230 V for current peak value n=20 rated value	157 A
— up to 400 V for current peak value n=20 rated value	157 A
— up to 500 V for current peak value n=20 rated value	157 A
— up to 690 V for current peak value n=20 rated value	157 A
— up to 1000 V for current peak value n=20 rated value	65 A
• at AC-6a	
— up to 230 V for current peak value n=30 rated value	105 A
— up to 400 V for current peak value n=30 rated value	105 A
— up to 500 V for current peak value n=30 rated value	105 A
— up to 690 V for current peak value n=30 rated value	105 A
— up to 1000 V for current peak value n=30 rated value	65 A
minimum cross-section in main circuit at maximum AC-1 rated value	95 mm <sup>2</sup>
<b>operational current for approx. 200000 operating cycles at AC-4</b>	
• at 400 V rated value	81 A
• at 690 V rated value	65 A
<b>operational current</b>	
• at 1 current path at DC-1	
— at 24 V rated value	160 A
— at 60 V rated value	160 A
— at 110 V rated value	18 A
— at 220 V rated value	3.4 A
— at 440 V rated value	0.8 A
— at 600 V rated value	0.5 A
• with 2 current paths in series at DC-1	
— at 24 V rated value	160 A

— at 60 V rated value	160 A
— at 110 V rated value	160 A
— at 220 V rated value	20 A
— at 440 V rated value	3.2 A
— at 600 V rated value	1.6 A
<b>● with 3 current paths in series at DC-1</b>	
— at 24 V rated value	160 A
— at 60 V rated value	160 A
— at 110 V rated value	160 A
— at 220 V rated value	160 A
— at 440 V rated value	11.5 A
— at 600 V rated value	4 A
<b>● at 1 current path at DC-3 at DC-5</b>	
— at 24 V rated value	160 A
— at 60 V rated value	7.5 A
— at 220 V rated value	0.6 A
— at 440 V rated value	0.17 A
— at 600 V rated value	0.12 A
<b>● with 2 current paths in series at DC-3 at DC-5</b>	
— at 24 V rated value	160 A
— at 60 V rated value	160 A
— at 110 V rated value	160 A
— at 220 V rated value	2.5 A
— at 440 V rated value	0.65 A
— at 600 V rated value	0.37 A
<b>● with 3 current paths in series at DC-3 at DC-5</b>	
— at 24 V rated value	160 A
— at 60 V rated value	160 A
— at 110 V rated value	160 A
— at 220 V rated value	160 A
— at 440 V rated value	1.4 A
— at 600 V rated value	0.75 A
<b>operating power</b>	
<b>● at AC-3</b>	
— at 230 V rated value	55 kW
— at 400 V rated value	90 kW
— at 500 V rated value	132 kW
— at 690 V rated value	160 kW
— at 1000 V rated value	90 kW
<b>● at AC-3e</b>	
— at 230 V rated value	55 kW
— at 400 V rated value	90 kW
— at 500 V rated value	132 kW
— at 690 V rated value	160 kW
— at 1000 V rated value	90 kW
<b>operating power for approx. 200000 operating cycles at AC-4</b>	
<b>● at 400 V rated value</b>	45 kW
<b>● at 690 V rated value</b>	65 kW
<b>operating apparent power at AC-6a</b>	
<b>● up to 230 V for current peak value n=20 rated value</b>	60 000 kVA
<b>● up to 400 V for current peak value n=20 rated value</b>	100 000 VA
<b>● up to 500 V for current peak value n=20 rated value</b>	130 000 VA
<b>● up to 690 V for current peak value n=20 rated value</b>	180 000 VA
<b>● up to 1000 V for current peak value n=20 rated value</b>	110 000 VA
<b>operating apparent power at AC-6a</b>	
<b>● up to 230 V for current peak value n=30 rated value</b>	40 000 VA
<b>● up to 400 V for current peak value n=30 rated value</b>	70 000 VA
<b>● up to 500 V for current peak value n=30 rated value</b>	90 000 VA
<b>● up to 690 V for current peak value n=30 rated value</b>	120 000 VA
<b>● up to 1000 V for current peak value n=30 rated value</b>	110 000 VA

<b>short-time withstand current in cold operating state up to 40 °C</b>	
<ul style="list-style-type: none"> <li>• limited to 1 s switching at zero current maximum</li> <li>• limited to 5 s switching at zero current maximum</li> <li>• limited to 10 s switching at zero current maximum</li> <li>• limited to 30 s switching at zero current maximum</li> <li>• limited to 60 s switching at zero current maximum</li> </ul>	2 900 A; Use minimum cross-section acc. to AC-1 rated value 2 084 A; Use minimum cross-section acc. to AC-1 rated value 1 480 A; Use minimum cross-section acc. to AC-1 rated value 968 A; Use minimum cross-section acc. to AC-1 rated value 801 A; Use minimum cross-section acc. to AC-1 rated value
<b>no-load switching frequency</b>	
<ul style="list-style-type: none"> <li>• at AC</li> <li>• at DC</li> </ul>	1 000 1/h 1 000 1/h
<b>operating frequency</b>	
<ul style="list-style-type: none"> <li>• at AC-1 maximum</li> <li>• at AC-2 maximum</li> <li>• at AC-3 maximum</li> <li>• at AC-3e maximum</li> <li>• at AC-4 maximum</li> </ul>	800 1/h 300 1/h 750 1/h 750 1/h 130 1/h
<b>Control circuit/ Control</b>	
<b>type of voltage of the control supply voltage</b>	AC/DC
<b>control supply voltage at AC</b>	
<ul style="list-style-type: none"> <li>• at 50 Hz rated value</li> <li>• at 60 Hz rated value</li> </ul>	96 ... 127 V 96 ... 127 V
<b>control supply voltage at DC rated value</b>	96 ... 127 V
<b>operating range factor control supply voltage rated value of magnet coil at DC</b>	
<ul style="list-style-type: none"> <li>• initial value</li> <li>• full-scale value</li> </ul>	0.8 1.1
<b>operating range factor control supply voltage rated value of magnet coil at AC</b>	
<ul style="list-style-type: none"> <li>• at 50 Hz</li> <li>• at 60 Hz</li> </ul>	0.8 ... 1.1 0.8 ... 1.1
<b>type of PLC-control input according to IEC 60947-1</b>	Type 2
<b>consumed current at PLC-control input according to IEC 60947-1 maximum</b>	20 mA
<b>voltage at PLC-control input rated value</b>	24 V
<b>operating range factor of the voltage at PLC-control input</b>	0.8 ... 1.1
<b>design of the surge suppressor</b>	with varistor
<b>apparent pick-up power</b>	
<ul style="list-style-type: none"> <li>• at minimum rated control supply voltage at AC               <ul style="list-style-type: none"> <li>— at 50 Hz</li> <li>— at 60 Hz</li> </ul> </li> <li>• at maximum rated control supply voltage at AC               <ul style="list-style-type: none"> <li>— at 60 Hz</li> <li>— at 50 Hz</li> </ul> </li> </ul>	190 VA 190 VA 280 VA 280 VA
<b>apparent pick-up power of magnet coil at AC</b>	
<ul style="list-style-type: none"> <li>• at 50 Hz</li> <li>• at 60 Hz</li> </ul>	280 VA 280 VA
<b>inductive power factor with closing power of the coil</b>	
<ul style="list-style-type: none"> <li>• at 50 Hz</li> <li>• at 60 Hz</li> </ul>	0.8 0.8
<b>apparent holding power</b>	
<ul style="list-style-type: none"> <li>• at minimum rated control supply voltage at DC</li> <li>• at maximum rated control supply voltage at DC</li> </ul>	2.1 VA 2.8 VA
<b>apparent holding power</b>	
<ul style="list-style-type: none"> <li>• at minimum rated control supply voltage at AC               <ul style="list-style-type: none"> <li>— at 50 Hz</li> <li>— at 60 Hz</li> </ul> </li> <li>• at maximum rated control supply voltage at AC               <ul style="list-style-type: none"> <li>— at 50 Hz</li> <li>— at 60 Hz</li> </ul> </li> </ul>	3.5 VA 3.5 VA 4.8 VA 4.8 VA
<b>inductive power factor with the holding power of the coil</b>	
<ul style="list-style-type: none"> <li>• at 50 Hz</li> <li>• at 60 Hz</li> </ul>	0.6 0.6

<b>closing power of magnet coil at DC</b>	320 W
<b>holding power of magnet coil at DC</b>	2.8 W
<b>closing delay</b>	
• at AC	35 ... 75 ms
• at DC	35 ... 75 ms
<b>opening delay</b>	
• at AC	80 ... 90 ms
• at DC	80 ... 90 ms
<b>arcing time</b>	10 ... 15 ms
<b>control version of the switch operating mechanism</b>	PLC-IN or Standard A1 - A2 (adjustable)
<b>Auxiliary circuit</b>	
number of NC contacts for auxiliary contacts instantaneous contact	2
number of NO contacts for auxiliary contacts instantaneous contact	2
operational current at AC-12 maximum	10 A
<b>operational current at AC-15</b>	
• at 230 V rated value	6 A
• at 400 V rated value	3 A
• at 500 V rated value	2 A
• at 690 V rated value	1 A
<b>operational current at DC-12</b>	
• at 24 V rated value	10 A
• at 48 V rated value	6 A
• at 60 V rated value	6 A
• at 110 V rated value	3 A
• at 125 V rated value	2 A
• at 220 V rated value	1 A
• at 600 V rated value	0.15 A
<b>operational current at DC-13</b>	
• at 24 V rated value	10 A
• at 48 V rated value	2 A
• at 60 V rated value	2 A
• at 110 V rated value	1 A
• at 125 V rated value	0.9 A
• at 220 V rated value	0.3 A
• at 600 V rated value	0.1 A
<b>contact reliability of auxiliary contacts</b>	1 faulty switching per 100 million (17 V, 1 mA)
<b>UL/CSA ratings</b>	
<b>full-load current (FLA) for 3-phase AC motor</b>	
• at 480 V rated value	180 A
• at 600 V rated value	192 A
<b>yielded mechanical performance [hp]</b>	
• for single-phase AC motor	
— at 230 V rated value	30 hp
• for 3-phase AC motor	
— at 200/208 V rated value	60 hp
— at 220/230 V rated value	75 hp
— at 460/480 V rated value	150 hp
— at 575/600 V rated value	200 hp
<b>contact rating of auxiliary contacts according to UL</b>	A600 / Q600
<b>Short-circuit protection</b>	
<b>design of the fuse link</b>	
• for short-circuit protection of the main circuit	
— with type of coordination 1 required	gG: 355 A (690 V, 100 kA)
— with type of assignment 2 required	gG: 315 A (690 V, 100 kA), aM: 200 A (690 V, 50 kA), BS88: 315 A (415 V, 50 kA)
• for short-circuit protection of the auxiliary switch required	gG: 10 A (500 V, 1 kA)
<b>Installation/ mounting/ dimensions</b>	
<b>mounting position</b>	with vertical mounting surface +/-90° rotatable, with vertical mounting surface +/- 22.5° tiltable to the front and back
<b>fastening method</b>	screw fixing

<b>height</b>	172 mm
<b>width</b>	120 mm
<b>depth</b>	170 mm
<b>required spacing</b>	
<ul style="list-style-type: none"> <li>● with side-by-side mounting <ul style="list-style-type: none"> <li>— forwards 20 mm</li> <li>— upwards 10 mm</li> <li>— downwards 10 mm</li> <li>— at the side 0 mm</li> </ul> </li> <li>● for grounded parts <ul style="list-style-type: none"> <li>— forwards 20 mm</li> <li>— upwards 10 mm</li> <li>— at the side 10 mm</li> <li>— downwards 10 mm</li> </ul> </li> <li>● for live parts <ul style="list-style-type: none"> <li>— forwards 20 mm</li> <li>— upwards 10 mm</li> <li>— downwards 10 mm</li> <li>— at the side 10 mm</li> </ul> </li> </ul>	

### Connections/ Terminals

<b>type of electrical connection</b>	
<ul style="list-style-type: none"> <li>● for main current circuit</li> <li>● for auxiliary and control circuit</li> <li>● at contactor for auxiliary contacts</li> <li>● of magnet coil</li> </ul>	Connection bar spring-loaded terminals Spring-type terminals Spring-type terminals
<b>width of connection bar</b>	17 mm
<b>thickness of connection bar</b>	3 mm
<b>diameter of holes</b>	9 mm
<b>number of holes</b>	1
<b>type of connectable conductor cross-sections</b>	
<ul style="list-style-type: none"> <li>● for AWG cables for main contacts</li> </ul>	4 ... 250 kcmil
<b>connectable conductor cross-section for main contacts</b>	
<ul style="list-style-type: none"> <li>● stranded</li> </ul>	25 ... 120 mm <sup>2</sup>
<b>connectable conductor cross-section for auxiliary contacts</b>	
<ul style="list-style-type: none"> <li>● solid or stranded</li> <li>● finely stranded with core end processing</li> <li>● finely stranded without core end processing</li> </ul>	0.25 ... 2.5 mm <sup>2</sup> 0.25 ... 1.5 mm <sup>2</sup> 0.25 ... 2.5 mm <sup>2</sup>
<b>type of connectable conductor cross-sections</b>	
<ul style="list-style-type: none"> <li>● for auxiliary contacts <ul style="list-style-type: none"> <li>— solid 2x (0.25 ... 2.5 mm<sup>2</sup>)</li> <li>— solid or stranded 2x (0,25 ... 2,5 mm<sup>2</sup>)</li> <li>— finely stranded with core end processing 2x (0.25 ... 1.5 mm<sup>2</sup>)</li> <li>— finely stranded without core end processing 2x (0.25 ... 2.5 mm<sup>2</sup>)</li> </ul> </li> <li>● for AWG cables for auxiliary contacts 2x (24 ... 14)</li> </ul>	
<b>AWG number as coded connectable conductor cross section</b>	
<ul style="list-style-type: none"> <li>● for auxiliary contacts</li> </ul>	24 ... 14

### Safety related data

<b>product function</b>	
<ul style="list-style-type: none"> <li>● mirror contact according to IEC 60947-4-1</li> <li>● positively driven operation according to IEC 60947-5-1</li> <li>● suitable for safety function</li> </ul>	Yes No Yes
suitability for use safety-related switching OFF	Yes; safety-related disconnection via A1 A2
<b>service life maximum</b>	20 a
<b>test wear-related service life necessary</b>	Yes
<b>proportion of dangerous failures</b>	
<ul style="list-style-type: none"> <li>● with low demand rate according to SN 31920</li> <li>● with high demand rate according to SN 31920</li> </ul>	40 % 73 %
<b>B10 value with high demand rate according to SN 31920</b>	1 000 000
<b>failure rate [FIT] with low demand rate according to SN 31920</b>	100 FIT



ISO 13849	
device type according to ISO 13849-1	3
overdimensioning according to ISO 13849-2 necessary	Yes
IEC 61508	
safety device type according to IEC 61508-2	Type A
Electrical Safety	
protection class IP on the front according to IEC 60529	IP00; IP20 with box terminal/cover
touch protection on the front according to IEC 60529	finger-safe, for vertical contact from the front with box terminal/cover

**Approvals Certificates**

General Product Approval

		<a href="#">Confirmation</a>			<a href="#">KC</a>
EG-Konf.			CCC	UL	

General Product Approval	EMV	Functional Safety	Test Certificates	Marine / Shipping
--------------------------	-----	-------------------	-------------------	-------------------

		<a href="#">Type Examination Certificate</a>	<a href="#">Type Test Certificates/Test Report</a>	<a href="#">Special Test Certificate</a>	
	RCM				ABS

Marine / Shipping	other
-------------------	-------

				<a href="#">Miscellaneous</a>	<a href="#">Confirmation</a>
DNV	LRS	PRS	RMRS		

other	Railway	Environment
-------	---------	-------------

<a href="#">Confirmation</a>	<a href="#">Miscellaneous</a>	<a href="#">Special Test Certificate</a>	<a href="#">Environmental Confirmations</a>
------------------------------	-------------------------------	--	---

**Further information**

Information on the packaging  
<https://support.industry.siemens.com/cs/ww/en/view/109813875>  
Information- and Downloadcenter (Catalogs, Brochures,...)  
<https://www.siemens.com/ic10>  
Industry Mall (Online ordering system)  
<https://mall.industry.siemens.com/mall/en/en/Catalog/product?mlfb=3RT1056-2NF36>  
Cax online generator  
<http://support.automation.siemens.com/WW/CAXorder/default.aspx?lang=en&mlfb=3RT1056-2NF36>  
Service&Support (Manuals, Certificates, Characteristics, FAQs,...)  
<https://support.industry.siemens.com/cs/ww/en/ps/3RT1056-2NF36>  
Image database (product images, 2D dimension drawings, 3D models, device circuit diagrams, EPLAN macros, ...)  
[http://www.automation.siemens.com/bilddb/cax\\_de.aspx?mlfb=3RT1056-2NF36&lang=en](http://www.automation.siemens.com/bilddb/cax_de.aspx?mlfb=3RT1056-2NF36&lang=en)  
Characteristic: Tripping characteristics, I<sup>2</sup>t, Let-through current  
<https://support.industry.siemens.com/cs/ww/en/ps/3RT1056-2NF36/char>  
Further characteristics (e.g. electrical endurance, switching frequency)  
<http://www.automation.siemens.com/bilddb/index.aspx?view=Search&mlfb=3RT1056-2NF36&objecttype=14&gridview=view1>

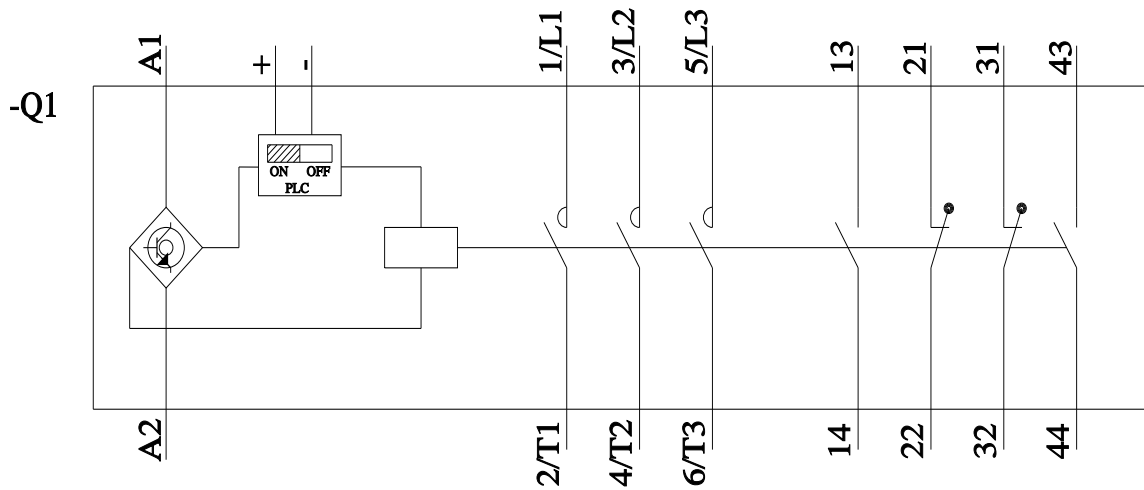
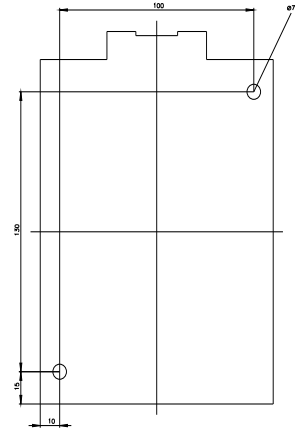
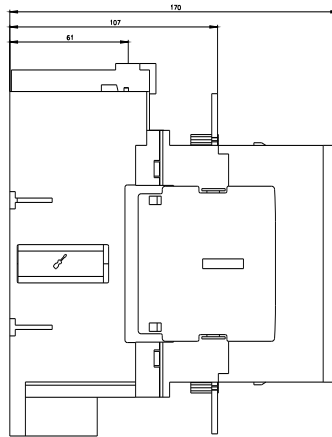
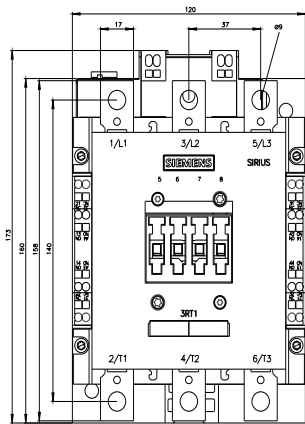

last modified:





