

## ExEIL580P-SC

Solid shaft with clamping flange

1...65536 pulses per revolution programmable (interpolated system)

### Overview

- Size ø58 mm
- Precise optical sensing (interpolated)
- Output signal level programmable (TTL or HTL)
- Clamping flange
- Connection axial, radial or tangential
- Pulses per revolution 1...65536, programmable
- High resistance to shock and vibrations
- Option 0122, Explosion protection zone 22



### Technical data

#### Technical data - electrical ratings

Voltage supply	4.75...30 VDC
Reverse polarity protection	Yes
Short-circuit proof	Yes
Consumption w/o load	≤70 mA
Initializing time	≤ 30 ms after power on
Pulses per revolution	1 ... 65536
Duty cycle	45...55 % typical at 1024, 2048 ppr (further see table Duty cycle)
Reference signal	Zero pulse 90° or 180°
Sensing method	Optical
Output frequency	≤300 kHz (TTL) ≤160 kHz (HTL)
Output signals	A+, B+, R+, A-, B-, R-
Output stages	TTL/RS422 HTL/push-pull
Programmable parameters	Output level TTL/HTL Pulse number 1...65536 Zero pulse width 90°/180° Zero pulse position Signal sequence
Interference immunity	EN 61000-6-2
Emitted interference	EN 61000-6-3

#### Technical data - mechanical design

Size (flange)	ø58 mm
---------------	--------

#### Technical data - mechanical design

Shaft type	ø10 x 20 mm, solid shaft with flat
Admitted shaft load	≤40 N axial ≤80 N radial
Flange	Clamping flange
Protection EN 60529	IP 65
Operating speed	≤12000 rpm (+20 °C) ≤11000 rpm (+40 °C) ≤8000 rpm (+60 °C)
Starting torque	≤0.015 Nm (+20 °C)
Material	Housing: aluminium die-cast Flange: aluminium Solid shaft: stainless steel
Ambient temperature	-20...+60 °C
Relative humidity	90 % non-condensing
Resistance	EN 60068-2-6 Vibration 30 g, 10-2000 Hz EN 60068-2-27 Shock 300 g, 6 ms
Explosion protection	II 3 D Ex tc IIIC T135°C Dc X (dust): see special conditions "X"
Connection	Flange connector M12, 8-pin Flange connector M23, 12-pin Cable
Weight approx.	300 g

# ExEIL580P-SC

Solid shaft with clamping flange

1...65536 pulses per revolution programmable (interpolated system)

## Terminal assignment

### Flange connector M23, 12-pin / cable

Pin	Core color	Assignment
1	pink	B-
2	–	–
3	blue	R+
4	red	R-
5	green	A+
6	yellow	A-
7	–	R-Set <sup>1)</sup>
8	grey	B+
9	–	–
10	white	GND
11	–	–
12	brown	UB

Screen: Connected to housing

Cable data: PUR, [4x2x0,14 mm<sup>2</sup>], bending radius >45,8 mm, outer diameter 6.1 mm

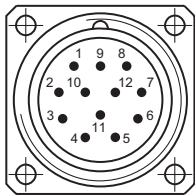

<sup>1)</sup> The R-Set input is used to set the reference pulse (zero pulse) on the current shaft position.  
R-Set = UB ≥ 200 ms

### Flange connector M12, 8-pin

Pin	Assignment
1	GND
2	UB
3	A+
4	A-
5	B+
6	B-
7	R+
8	R-



## Output signals

Zero pulse electrical 90° A&B high  
(Factory setting at clockwise rotation (CW)  
in view of the encoder flange)

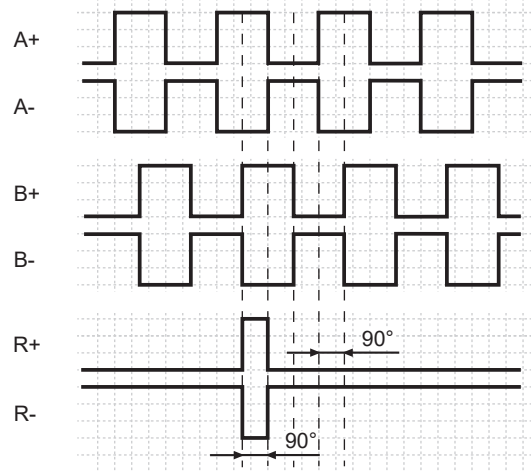

Zero pulse electrical 180° B low  
(at clockwise rotation (CW)  
in view of the encoder flange)

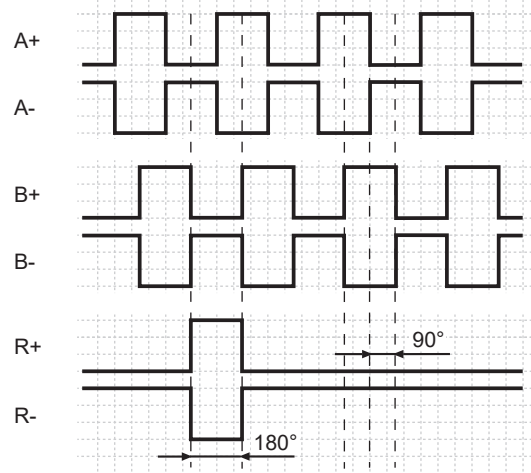

## Trigger level

Outputs	TTL/RS422
Output level High	≥2.5 V
Output level Low	≤0.5 V
Load	≤20 mA

Outputs	HTL/Push-pull
Output level High	≥UB -3 V
Output level Low	≤1.5 V
Load	≤20 mA

## ExEIL580P-SC

Solid shaft with clamping flange

1...65536 pulses per revolution programmable (interpolated system)

### Duty cycle

The duty cycle (D) is defined as the time ratio between the HIGH pulse duration (H) and the pulse period (T).

System-induced and depending on the pulse number, the measured values may vary which has an impact on speed and position acquisition. Binary pulse numbers are recommended for speed feedback.

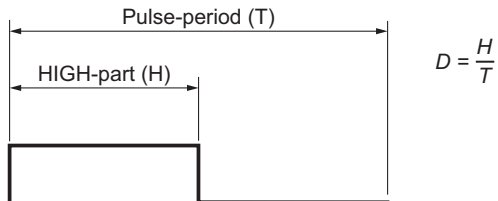

Programmed pulse number	Scan ratio (D) (maximum)	Jitter (+/-) (maximum)
1...1023	45...55 %	5%
1024, 2048	45...55 %	5%
1025...5000	40...60 %	10%
8192, 16384	35...85 %	15%
5001...10000	22...78 %	28%
32768	25...75 %	25%
65536	15...85 %	35%
all other	Jitter[%]=(programmed pulse number -10000)*0,0007%+28%	

## ExEIL580P-SC

Solid shaft with clamping flange

1...65536 pulses per revolution programmable (interpolated system)

### Explosion protection

 II 3 D Ex tc IIIC T135°C Dc X (dust)

#### General- and Special conditions „X“:

##### Only put the device into operation if ...

- all necessary precautions have been taken by the operator to make sure device and connector are fully protected against mechanical impacts or shocks in compliance with EN 60079-0, section 26.4.2 (Special conditions „X“).
- the connection is mechanically or electrically secured to prevent any interrupt while the contact is live (Special conditions „X“).
- it has been ensured the electrical connection of product variants with cable outlet or cable couplings is outside zone 22 (Special conditions „X“).
- it has been ensured the maximum operating speed in relation to the ambient temperature is within the specifications on the table „Maximum rotation speed below“ (Special conditions „X“).
- the specifications on the product label match the on-site conditions for use in hazardous areas (EX) (device group, category, zone, temperature class resp. maximum surface temperature).
- the specifications on the product label comply with the prevailing grid conditions.
- the device shows no visible trace of damage (resulting from transport or storage), and
- it has been ensured no explosive atmosphere, oils, acids, gases, vapors, radiation etc. are present during installation.

Observe standard EN 60079-14 for installation and commissioning.

**Device operation must observe the installation and operating instructions. The intended use and application of the device comes under the relevant legislation as well as applicable directives and standards.**

#### Maximum rotation speed

	ambient temperature	rotation speed
solid shaft	20 °C	≤ 12000 rpm
	40 °C	≤ 11000 rpm
	60 °C	≤ 8000 rpm
through hollow shaft	20 °C	≤ 6000 rpm
	40 °C	≤ 4500 rpm
	60 °C	≤ 2500 rpm
blind hollow shaft	20 °C	≤ 8000 rpm
	40 °C	≤ 8000 rpm
	60 °C	≤ 5000 rpm

# ExEIL580P-SC

Solid shaft with clamping flange

1...65536 pulses per revolution programmable (interpolated system)

## Dimensions

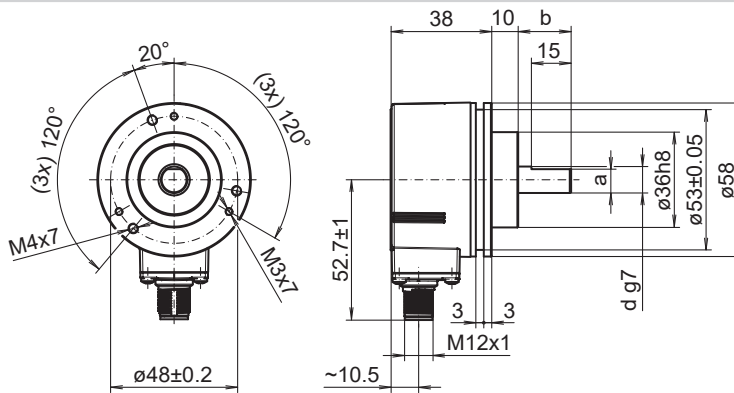

Clamping flange, flange connector M12, radial

d g7	a	b
ø9.525	8.64	20.32
ø10	9.	20

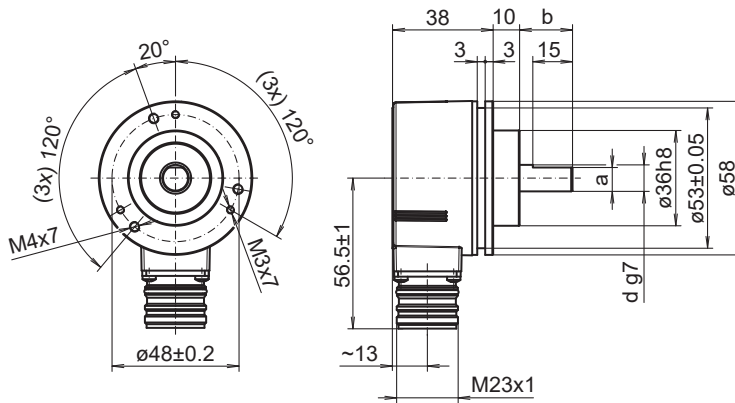

Clamping flange, flange connector M23, radial

d g7	a	b
ø9.525	8.64	20.32
ø10	9.	20

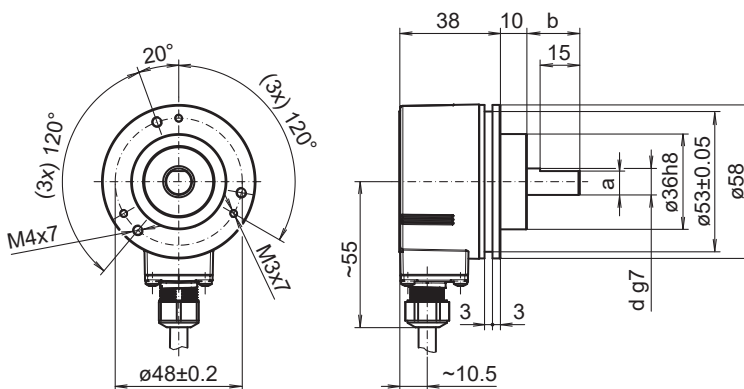

Clamping flange, cable, radial

d g7	a	b
ø9.525	8.64	20.32
ø10	9.	20

# ExEIL580P-SC

Solid shaft with clamping flange

1...65536 pulses per revolution programmable (interpolated system)

## Dimensions

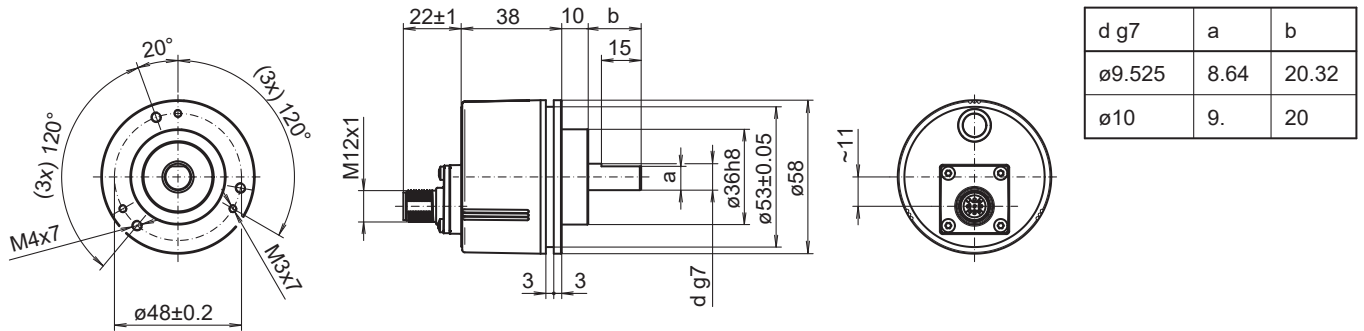

Clamping flange, flange connector M12, axial

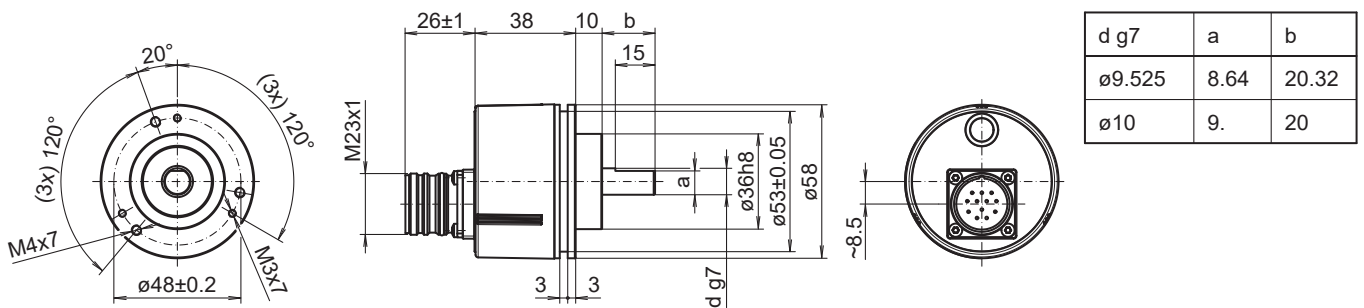

Clamping flange, flange connector M23, axial

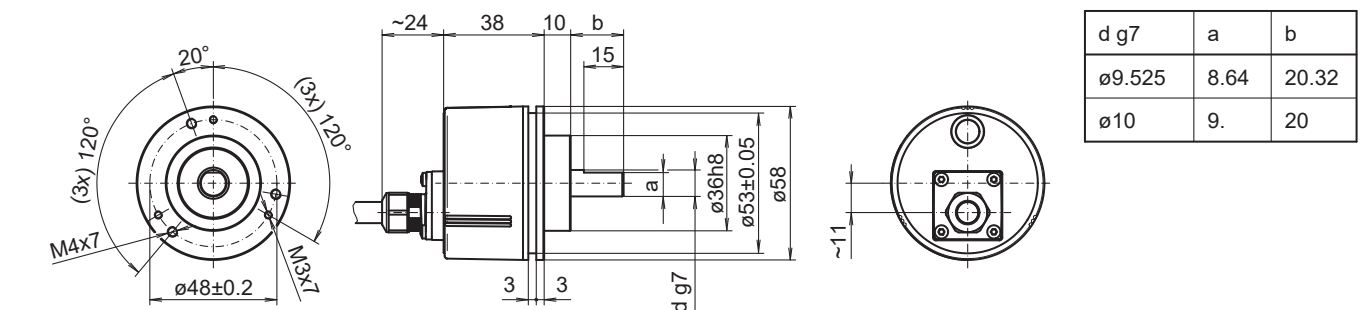

Clamping flange, cable, axial

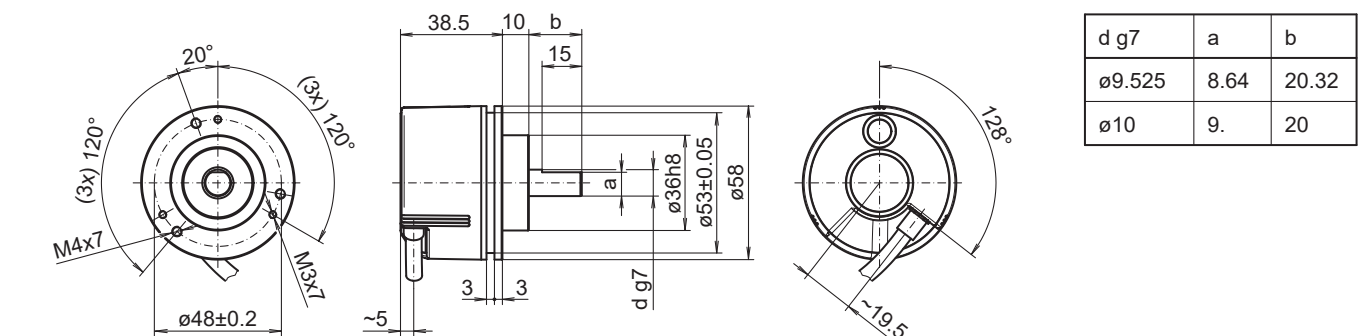

Clamping flange, cable, tangential

# ExEIL580P-SC

Solid shaft with clamping flange

1...65536 pulses per revolution programmable (interpolated system)

**Ordering reference**

	<b>ExEIL580P</b>	<b>- S C</b>	<b>##</b>	<b>. 5</b>	<b>##</b>	<b>#</b>	<b>. 01024</b>	<b>. F</b>	<b>/ 0122</b>
<b>Product</b>	ExEIL580P								
<b>Shaft type</b>	Solid shaft	S							
<b>Flange (shaft)</b>	Clamping flange, centering collar $\varnothing 36 \times 10$ mm, pitch circle diameter 48 mm - 3xM3/3xM4	C							
<b>Shaft</b>	$\varnothing 10 \times 20$ mm, with flat		10						
	$\varnothing 3/8 \times 4/5$ ( $\varnothing 9.525 \times 20.32$ mm), with flat		U3						
<b>Protection class</b>	IP 65				5				
<b>Connection</b>	Flange socket axial, M12, 8-pin, male contacts, CCW					A			
	Flange socket radial, M12, 8-pin, male contacts, CCW					B			
	Flange socket axial, M23, 12-pin, male contacts, CCW					D			
	Flange socket radial, M23, 12-pin, male contacts, CCW					F			
	Cable radial, 2 m					L			
	Cable tangential, 1 m					P			
	Cable tangential, 2 m					Q			
	Cable radial, 1 m					R			
	Cable axial, 1 m					T			
	Cable axial, 2 m					U			
<b>Voltage supply / output</b>	4,75...30 VDC, HTL/push pull, 6 channel ( $V_{out}=V_{in}$ )						Q		
	4,75...30 VDC, TTL/RS422 6 channel ( $V_{out}=5V$ )						F		
<b>Pulses programmable</b>	1...65536 programmable (factory setting: 1024)						01024		
<b>Operating temperature</b>	-20...+60 °C							F	
<b>Optionen BT</b>	ATEX Zone 22								0122

 (Factory setting: 1024 ppr,  $V_{out} = 5$  VDC TTL, signal sequence A leading B (CW), zero pulse 90° A&B high)

## ExEIL580P-SC

Solid shaft with clamping flange

1...65536 pulses per revolution programmable (interpolated system)

### Accessories

#### Mounting accessories

11065915	Coupling CPS25 (L=19, D1=04 / D2=10)
11065918	Coupling CPS25 (L=19, D1=07 / D2=10)
11065920	Coupling CPS25 (L=19, D1=08 / D2=10)
11065921	Coupling CPS25 (L=19, D1=09 / D2=10)
11065922	Coupling CPS25 (L=19, D1=10 / D2=06)
11065923	Coupling CPS25 (L=19, D1=10 / D2=10)
11065924	Coupling CPS25 (L=19, D1=10 / D2=11)
11065925	Coupling CPS25 (L=19, D1=10 / D2=12)
10141132	Spring washer coupling (D1=6 / D2=10)
10141133	Spring washer coupling (D1=10 / D2=10)
11034138	Spring washer coupling (D1=10 / D2=16)
11034140	Spring washer coupling (D1=10 / D2=14)
11034141	Spring washer coupling (D1=10 / D2=12)
11050507	Bellows coupling (D1=06 / D2=10)
11101781	Double loops coupling (D1=10 / D2=10)
10125051	Mounting adaptor
11065545	Set of eccentric fixings type A
11101893	Spring encoder arm

#### Programming accessories

11120657	Handheld Programming Tool Z-PA-EI-H
11120547	PC Programming Tool Z-PA-EI-P
11119280	Connection cable connector M12 / connector D-SUB, 0.2 m
11119720	Connection cable connector M12 / connector D-SUB, 1 m
11119257	Connection cable connector M23 (CW) / connector D-SUB, 0.2 m
11119723	Connection cable connector M23 (CW) / connector D-SUB, 1 m